

WM 710 Adhesive Dispensing Pneumatic Gun



High-flow cold adhesive gun provides sharp cutoff for intermittent and continuous production.



The Nordson WM 710 pneumatic bead gun features an innovative reverse-needle stroke function to produce excellent adhesive cutoff. The integrated needle and seat closes against the direction of material flow. This causes excess material to be pulled back into the gun significantly reducing nozzle dripping.

The WM 710 pneumatic gun is ideal for slot nozzle applications and low- to medium-speed intermittent packaging, corrugated, and bag-and-sack manufacturing. Fast air-open, air-close gun operation complements clean cutoff to provide reliable pattern uniformity.

Gun cycle times of 10.5 milliseconds (12.7 W) or 12 milliseconds (5.4 W) and a minimum service life of 30 million cycles deliver reliable response and long service life.

Efficient operation improves pattern and product quality.

- **Reverse-needle stroke action** delivers accurate cutoff and retards adhesive build-up on the nozzle.
- **Integrated needle-and-seat design** improves adhesive flow.
- **Narrow body profile** fits easily on most parent machinery and slot nozzles.

- **Compact vertical gun-mount bracket** simplifies installation and service.
- **Vertical micro-adjust control** facilitates critical gun positioning.
- **Efficient control piston** handles a wide range of adhesive types and viscosities.
- **Removable gun cartridge** expedites servicing without bracket disassembly and time-consuming repositioning.
- **Quick-disconnect air fitting and pre-mounted solenoid** speed installation.
- **Corrosion-resistant materials on all wetted components and a stainless-steel needle** help prolong gun life.

WM 710 Adhesive Dispensing Pneumatic Gun



Compact body size fits easily on most parent machinery and slot nozzles.

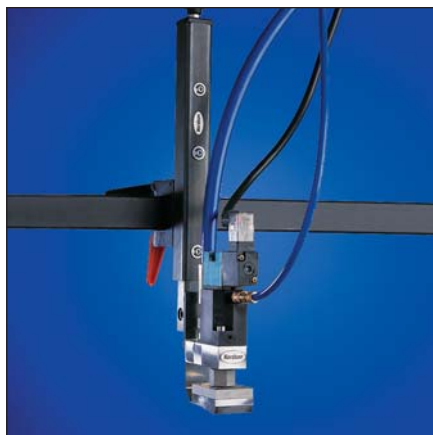

Efficient gun-mount bracket provides vertical micro-adjustment for critical positioning.



A wide selection of nozzle orifice diameters and pattern plates meets diverse pattern requirements.

Specifications

Working Hydraulic Pressure	36 bar (529 psi)
Maximum Hydraulic Pressure	100 bar (1470 psi)
Operating Air Pressure	0.5 to 6 bar (7 to 88 psi), 4 bar (59 psi) recommended
Minimum Cycle Time*	10.5 ms (12.7 W), 12.0 ms (5.4 W)
Nozzle Diameter Range	0.3 to 1.5 mm (0.012 to 0.059 in.)
Pattern Coating Width	Up to 100 mm (3.94 in.)
Connection Fitting	1/2-20 UNF
Electrical Service	230 VAC, 50/60 Hz, 24 VDC or 110 VAC solenoid
Weight	0.45 kg (1.0 lb)

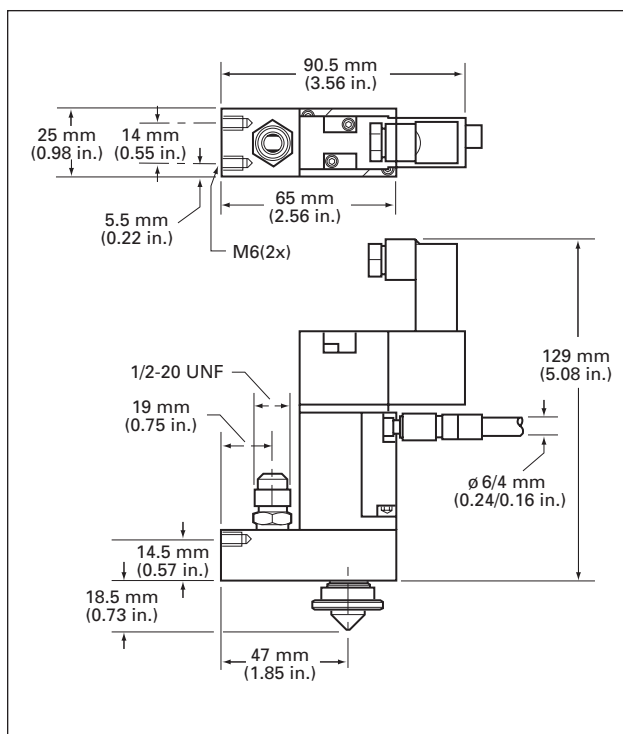

* Cycle times based on an adhesive viscosity of 900 centipoise. Actual cycle time will vary depending on adhesive viscosity and characteristics.



For more information, talk with your Nordson representative or contact your Nordson regional office.

United States
Duluth, Georgia
Telephone: (800) 683-2314
Toll-free Facsimile:
(866) 667-3329

Canada
Markham, Ontario
Telephone: (800) 463-3200
Facsimile: (905) 475-8821

Europe
Udenhout, The Netherlands
Telephone: (31) 13-511-8777
Facsimile: (31) 13-511-3995

Japan
Tokyo, Japan
Telephone: (81) 3-5762-2700
Facsimile: (81) 3-5762-2701

**Asia/Australia/
Latin America**
Amherst, Ohio
Telephone: (440) 985-4797
Facsimile: (440) 985-1096

www.nordson.com/packaging



When you expect more.®